



Patent pending

Nut Cooling Ball Screws for High Precision Machine Tools

This new ball screw can simplify ball screw cooling to make machine tools more speedy and precise. Even long ball screws with a hollow shaft that are difficult to cool can be cooled. This product can meet the needs for improved precision for a wide range of machining tools -large and small.



Cooling effects

By optimizing the cooling structure inside the nut, cooling capacity equivalent to hollow shaft cooling has been achieved. The nut in contact with the table is cooled, so that heat conduction from the table to the ball screw is blocked. Moreover, by cooling hollow shaft in parallel, the screw shaft and ball nut can be cooled at the same time for even more precise temperature control.

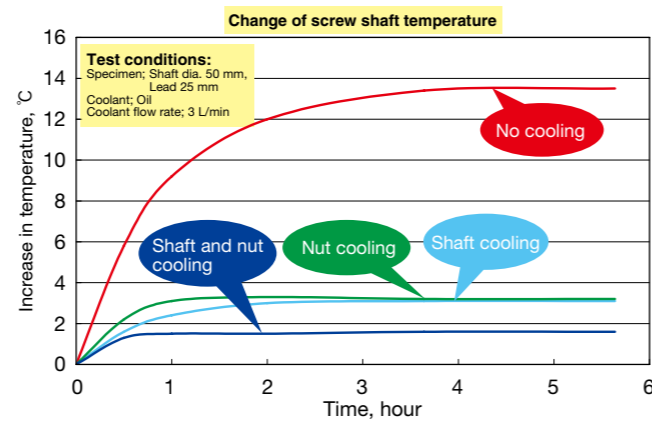

Internal design in consideration of preload torque change

The nut cooling ball screw has double contact-point preload in the tensile direction. This prevents an increase in preload torque when the nut is cooled, enabling effective cooling of the ball screw.

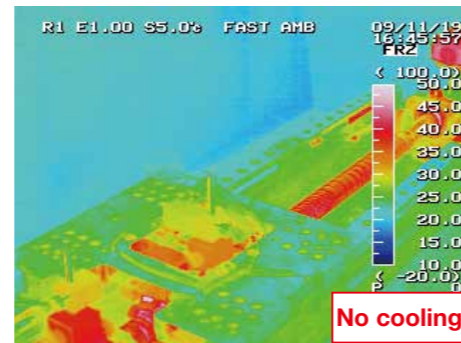
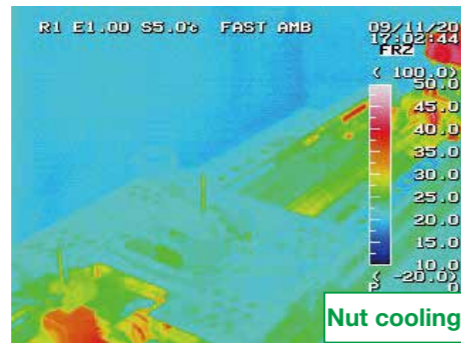
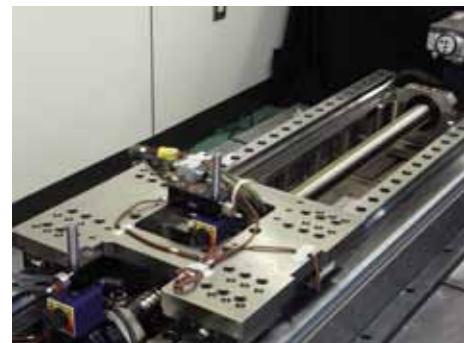

Cooling structure

The cooling fluid goes in a balanced way through the nut. Double nuts have separate coolant routes for each nut for efficient cooling. Cooling fluid does not go through the inside of spacers, so coolant fluid does not leak even when preload drops and airtightness is maintained.

Cooling structure

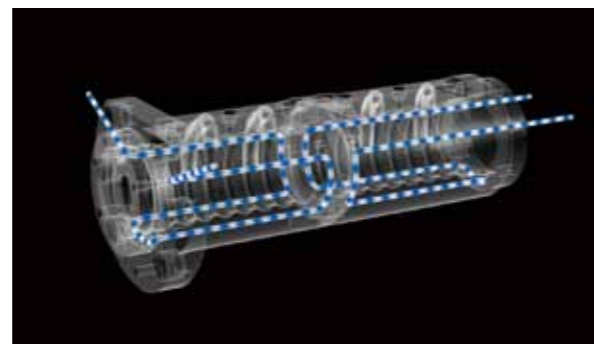

Improved handling

Ball screws can be cooled by simply attaching piping to the exterior flange part.* Sliding seals and rotary joints that are required for hollow shaft cooling are not needed. Dimensions for mounting area (without nut cooling) are the same as conventional products, so the nut cooling can be implemented without changing machine designs.

*When cooling double nuts, piping is required on the nut end face on the other side of the flange.

Long ball screws can be cooled at a low cost

Since these products are suitable for long ball screws for which hollow hole processing is difficult, improved precision of large machine tools can be achieved at a low cost.

Nut cooling ball screws: dimension chart

● Single nut cooling ball screws (for HMD series, nut type: EM)

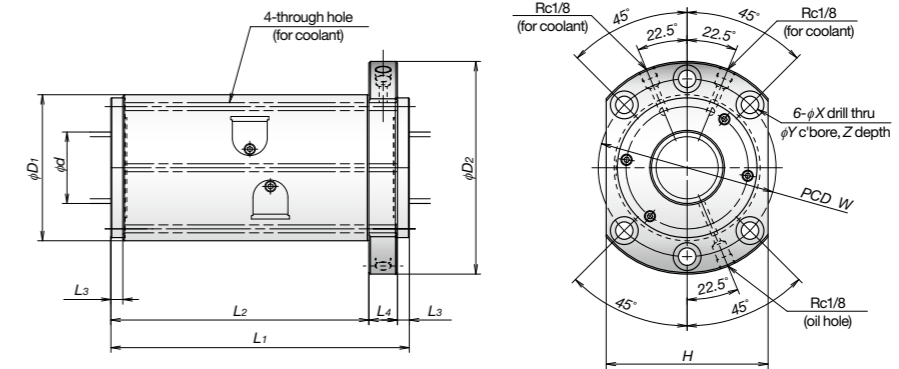

• Option symbols "NC" are included in the assembly part number. (Example : W4012-123ZMNCX-C5Z20)

Applicable dimensions for HMD Series

Model No.	Shaft dia. d	Lead l	Nut dimensions										
			D ₁	D ₂	H	L ₁	L ₂	L ₃	L ₄	W	X	Y	Z
EM4016-4E	40	16	86	128	96	166	140.5	7.5	18	106	11	17.5	11
EM4020-6E		20				156	130.5	7.5	18				
EM4025-6E		25				188	162.5	7.5	18				
EM4030-6E		30				219	193.5	7.5	18				
EM4516-4E	45	16	92	134	102	166	140.5	7.5	18	112	11	17.5	11
EM4520-6E		20				156	130.5	7.5	18				
EM4525-6E		25				188	162.5	7.5	18				
EM5016-4E	50	16	98	140	107	166	140.5	7.5	18	118	11	17.5	11
EM5020-6E		20				156	130.5	7.5	18				
EM5025-6E		25				188	162.5	7.5	18				
EM5030-6E		30				219	193.5	7.5	18				
EM6316-4E	63	16	122	180	138	176	139	9	28	150	18	26	17.5

● Double nut cooling ball screws (tube-type nut, nut type: DFT)

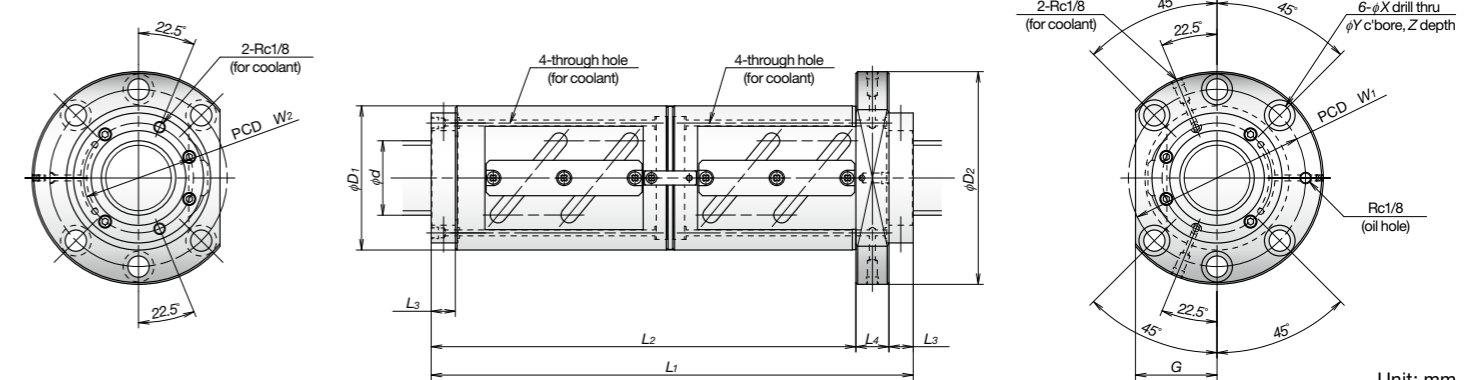

Model No.	Shaft dia. d	Lead l	Nut dimensions											
			D ₁	D ₂	L ₁	L ₂	L ₃	L ₄	G	W ₁	X	Y	Z	W ₂
DFT5010-7.5	50	10	93	135	303	275	10	18	51	113	11	17.5	11	73
DFT5012-5		12	100	146	279	245	12	22	55	122	14	20	13	78
DFT5016-5		16	100	146	344	306	16	22						
DFT5020-3		20	100	146	327	279	20	28						
DFT5510-5	55	10	102	144	243	215	10	18	54	122	11	17.5	11	80
DFT6310-7.5	63	10	108	154	307	275	10	22	58	130	14	20	13	88
DFT6312-5		12	115	161	279	245	12	22	61	137	14	20	13	91
DFT6316-5		16	122	180	350	306	16	28	69	150	18	26	17.5	93
DFT6320-5		20	122	180	407	359	20	28						
DFT8010-5	80	10	130	176	247	215	10	22	66	152	14	20	13	108
DFT8012-5		12	136	182	279	245	12	22	68	158	14	20	13	110
DFT8016-5		16	143	204	350	306	16	28	77	172	18	26	17.5	112
DFT8020-5		20	143	204	407	359	20	28						
DFT10012-5	100	12	160	220	285	245	12	28	82	188	18	26	17.5	134
DFT10016-5		16	170	243	354	306	16	32	91	205	22	32	21.5	136
DFT10020-5		20	170	243	411	359	20	32						

• Option symbols "NC" are included in the assembly part number. (Example : W5012-123DNC-C5Z10)

Operating suggestions

If heat impact from the bearing is too great, separate cooling for bearing and surrounding areas is recommended. For details, please contact NSK.

Worldwide Sales Offices

P: Phone ☆: Head Office

NSK LTD. HEADQUARTERS, TOKYO JAPAN

INDUSTRIAL MACHINERY BUSINESS DIVISION-HEADQUARTERS P: +81-3-3779-7227
 AUTOMOTIVE BUSINESS DIVISION-HEADQUARTERS P: +81-3-3779-7189

Africa

South Africa:

NSK SOUTH AFRICA (PTY) LTD.

JOHANNESBURG P: +27-11-458-3600

Aisia and Oceania

Australia:

NSK AUSTRALIA PTY. LTD.

MELBOURNE ☆ P: +61-3-9765-4400
 SYDNEY P: +61-2-8843-8100
 BRISBANE P: +61-7-3347-2600
 PERTH P: +61-8-9256-5000

New Zealand:

NSK NEW ZEALAND LTD.

AUCKLAND P: +64-9-276-4992

China:

NSK HONG KONG LTD.

HONG KONG ☆ P: +852-2739-9933
 SHENZHEN P: +86-755-25904886

NSK (SHANGHAI) TRADING CO., LTD.

JIANGSU P: +86-512-5796-3000

NSK (CHINA) INVESTMENT CO., LTD.

JIANGSU ☆ P: +86-512-5796-3000
 BEIJING P: +86-10-6590-8161
 TIAN JIN P: +86-22-8319-5030
 CHANGCHUN P: +86-431-8898-8682
 SHENYANG P: +86-24-2334-2868
 DALIAN P: +86-411-8800-8168
 NANJING P: +86-25-8472-6671
 FUZHOU P: +86-591-8380-1030
 WUHAN P: +86-27-8556-9630
 QINGDAO P: +86-532-5568-3877
 GUANGZHOU P: +86-20-3817-7800
 CHANGSHA P: +86-731-8571-3100
 LUOYANG P: +86-379-6069-6188
 XI'AN P: +86-29-8765-1896
 CHONGQING P: +86-23-6806-5310
 CHENGDU P: +86-28-8528-3680

NSK CHINA SALES CO., LTD.

JIANGSU P: +86-512-5796-3000

India:

NSK INDIA SALES CO.PVT.LTD.

CHENNAI ☆ P: +91-44-2847-9600
 GURGAON P: +91-124-4104-530
 MUMBAI P: +91-22-2838-7787

Indonesia:

PT. NSK INDONESIA

JAKARTA P: +62-21-252-3458

Korea:

NSK KOREA CO., LTD.

SEOUL P: +82-2-3287-0300

Malaysia:

NSK BEARINGS (MALAYSIA) SDN.BHD.

SHAH ALAM ☆ P: +60-3-7803-8859
 PRAI P: +60-4-3902275
 JOHOR BAHRU P: +60-7-3546290
 IPOH P: +60-5-2555000

Philippines:

NSK REPRESENTATIVE OFFICE

MANILA P: +63-2-893-9543

Singapore:

NSK INTERNATIONAL (SINGAPORE) PTE LTD.

SINGAPORE P: +65-6496-8000

NSK SINGAPORE (PRIVATE) LTD.

SINGAPORE P: +65-6496-8000

Taiwan:

TAIWAN NSK PRECISION CO., LTD.

TAIPEI ☆ P: +886-2-2509-3305
 TAICHUNG P: +886-4-2311-7978
 TAINAN P: +886-6-505-5861

TAIWAN NSK TECHNOLOGY CO., LTD.

TAIPEI ☆ P: +886-2-2509-3305
 TAICHUNG P: +886-4-2358-2945
 TAINAN P: +886-6-505-5861

Thailand:

NSK BEARINGS (THAILAND) CO., LTD.

BANGKOK P: +66-2320-2555

Vietnam:

NSK VIETNAM CO., LTD.

HANOI P: +84-4-3955-0159

NSK REPRESENTATIVE OFFICE

HO CHI MINH CITY P: +84-8-3822-7907

Europe

United Kingdom:

NSK EUROPE LTD. (EUROPEAN HEADQUARTERS)

MAIDENHEAD P: +44-1628-509-800

NSK UK LTD.

NEWARK P: +44-1636-605-123

France:

NSK FRANCE S.A.S.

PARIS P: +33-1-30-57-39-39

Germany:

NSK DEUTSCHLAND GMBH

DUSSELDORF ☆ P: +49-2102-4810
 STUTTGART P: +49-711-79082-0
 WOLFSBURG P: +49-5361-27647-10

Italy:

NSK ITALIA S.P.A.

MILANO P: +39-299-5191

Netherlands:

NSK EUROPEAN DISTRIBUTION CENTRE B.V.

TILBURG P: +31-13-4647647

Poland:

NSK REPRESENTATIVE OFFICE

WARSAW P: +48-22-645-1525

Russia:

NSK POLSKA SP. Z O.O.

SAINT-PETERSBURG P: +7-812-332-5071

Spain:

NSK SPAIN S.A.

BARCELONA P: +34-93-433-5775

Turkey:

NSK RULMANLARI ORTA DOGU TIC. LTD. STL

ISTANBUL P: +90-216-477-7111

UAE:

NSK BEARINGS GULF TRADING CO.

DUBAI P: +971-4-804-8200

North and South America

United States of America:

NSK AMERICAS, INC. (AMERICAN HEADQUARTERS)

ANN ARBOR P: +1-734-913-7500

NSK CORPORATION

ANN ARBOR P: +1-734-913-7500

NSK PRECISION AMERICA, INC.

FRANKLIN ☆ P: +1-317-738-5000

NSK LATIN AMERICA, INC.

MIAMI P: +1-305-477-0605

Canada:

NSK CANADA INC.

TORONTO ☆ P: +1-905-890-0740

NSK CORPORATION

MONTREAL P: +1-514-633-1220

NSK CORPORATION

VANCOUVER P: +1-877-994-6675

Argentina:

NSK ARGENTINA SRL

BUENOS AIRES P: +54-11-4704-5100

Brazil:

NSK BRASIL LTDA.

SAO PAULO ☆ P: +55-11-3269-4786

NSK CORPORATION

BELO HORIZONTE P: +55-31-3274-2591

NSK CORPORATION

JOINVILLE P: +55-47-3422-5445

NSK CORPORATION

PORTO ALEGRE P: +55-51-3222-1324

NSK CORPORATION

RECIFE P: +55-81-3326-3781

Peru:

NSK PERU S.A.C.

LIMA P: +51-1-652-3372

Mexico:

NSK RODAMIENTOS MEXICANA, S.A. DE C.V.

MEXICO CITY ☆ P: +52-55-3682-2900

NSK CORPORATION

MONTERREY P: +52-81-8000-7300

<As of June 2013>

For the latest information, please refer to the NSK website.

www.nsk.com

NSK Ltd. has a basic policy not to export any products or technology designated as controlled items by export-related laws. When exporting the products in this brochure, the laws of the exporting country must be observed. Specifications are subject to change without notice and without any obligation on the part of the manufacturer. Every care has been taken to ensure the accuracy of the data contained in this brochure, but no liability can be accepted for any loss or damage suffered through errors or omissions. We will gratefully acknowledge any additions or corrections.

For more information about NSK products, please contact: _____

